



CABINETS & ACCESSORIES

WALL CABINET

B

PRODUCT SPECIFICATIONS

Linxcom 19" wall-mounted cabinets are a cost-effective solution that is both aesthetically pleasing and durable.

Designed to be installed in data centres, equipment rooms and office environments to mount telecommunication, data communication, security, broadcasting and other electronic equipment.

This Cabinet Features a Double Section welded design with lockable single front glass door and solid back panel with mounting bracket.

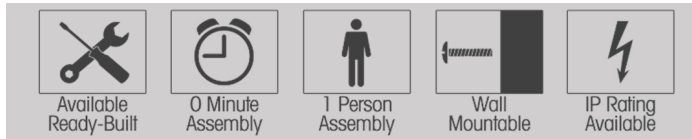

TECHNICAL SPECIFICATIONS

Construction Type	Welded
Cable Entries	Top and Bottom
Lockable Doors	Front and Rear Section
Mounting Profiles	Front and Rear
Fan Cut-Outs	Top Only



CABINETS & ACCESSORIES

WALL CABINET

B

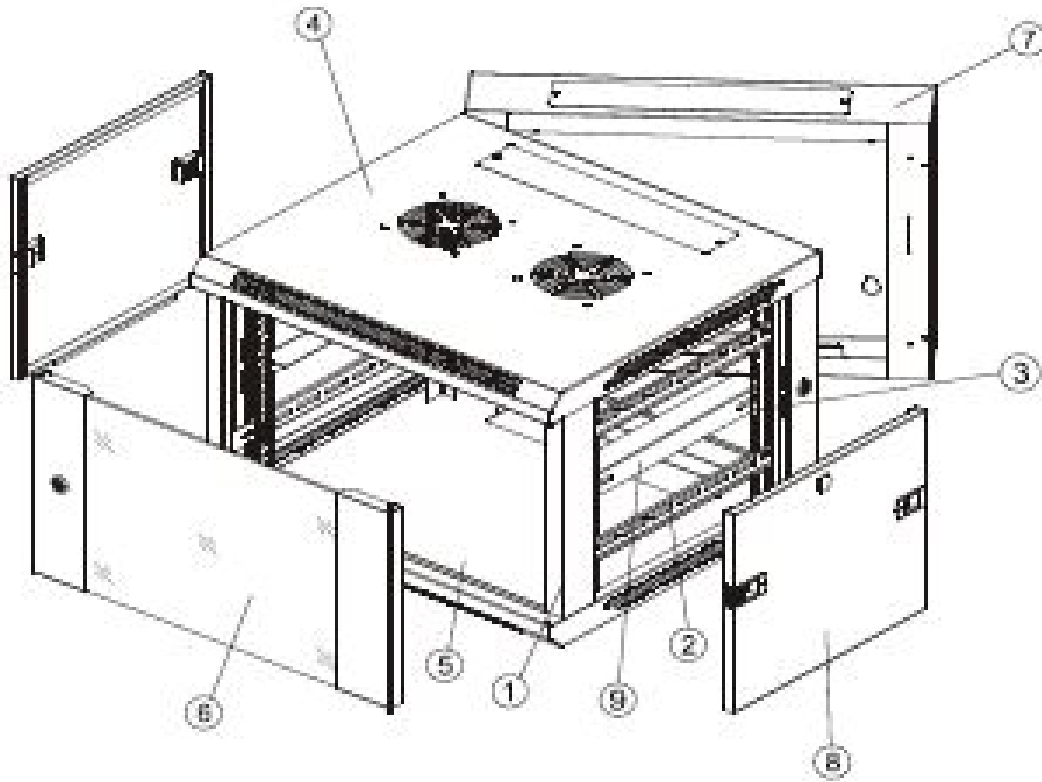

PRODUCT SPECIFICATIONS

Part	Material	Surface
Top Panel	SPCC Cold-Rolled Steel 1.0mm	Power Coated
Frame	SPCC Cold-Rolled Steel 1.0mm	Power Coated
Cable Entry Cover	SPCC Cold-Rolled Steel 1.0mm	Power Coated
Front Door	Toughened Glass 5mm/ SPCC Cold-Rolled Steel 1.2mm	Power Coated
Side Panel	SPCC Cold-Rolled Steel 1.0mm	Power Coated
Back Panel	SPCC Cold-Rolled Steel 1.2mm	Power Coated
Bottom Panel	SPCC Cold-Rolled Steel 1.0mm	Power Coated
Mounting Bracket	SPCC Cold-Rolled Steel 1.2mm	Power Coated



CABINETS & ACCESSORIES

WALL CABINET

B

ORDERING INFORMATION						
Model	Colour	Width (mm)	Depth (mm)	U size	Height (mm)	Product Code
B	Black, Grey	600	550	6	370	LXMBXX6506
B	Black, Grey	600	600	6	370	LXMBXX6606
B	Black, Grey	600	550	9	500	LXMBXX6509
B	Black, Grey	600	600	9	500	LXMBXX6609
B	Black, Grey	600	550	12	635	LXMBXX6512
B	Black, Grey	600	600	12	635	LXMBXX6612
B	Black, Grey	600	550	15	770	LXMBXX6515
B	Black, Grey	600	600	15	770	LXMBXX6615
B	Black, Grey	600	550	18	900	LXMBXX6518
B	Black, Grey	600	600	18	900	LXMBXX6618

Note: Replace **xx** with the intial for your desired colour.