



Cabinets & Racks

Wall-Mounted Cabinet – Model Q



Linxcom 19" wall-mounted cabinets and racks are a cost-effective solution that is both aesthetically pleasing and durable. Designed to be installed in data centres, equipment rooms and office environments to mount telecommunication, data communication, security, broadcasting and other electronic equipment.

Features & Benefits

- Available in a variety of heights and depths
- Available in grey or black - more colours available
- Tempered glass 200° swing front door with lock
- Adjustable front and rear mounting rails with U markings
- 600mm wide body
- Quick removable side doors
- Vented top and bottom panels enabling ventilation and reliable operation
- Compatible with various 19" accessories
- Maximum 50kgs UDL loading capacity
- 2x 120mm fan cut-outs
- Strong welded chassis construction, only available ready-built



50kgs UDL Capacity



0 Minute Assembly



Available Ready-Built



IP Rating Available

Below we have our standard stock sizes for height, widths and depths, but we also offer custom-built cabinets. If you require a specification which is not specified, then contact us and we can assist you.

Technical Specifications

Build Type	Welded	Assembly	Ready-built
Chassis Material	1.2mm cold-rolled steel	Maximum Load Capacity	50kgs UDL
Front Door Material	5.0mm toughened glass	IP Rating	20
Cable Entries	2 (1x top, 1x bottom)	Mounting Profiles	Front and rear
Lockable Doors	Front	Fan Cut-Outs	2x 120mm

Available Configurations

Capacity (U)	Height (mm)	Widths (mm)	Depths (mm)	Colours
6	310	540	450, 600	Black, Grey
9	445	540	450, 600	Black, Grey
12	580	540	450, 600	Black, Grey
15	710	540	450, 600	Black, Grey



Cabinets & Racks

Wall-Mounted Cabinet – Model Q

Technical Drawings

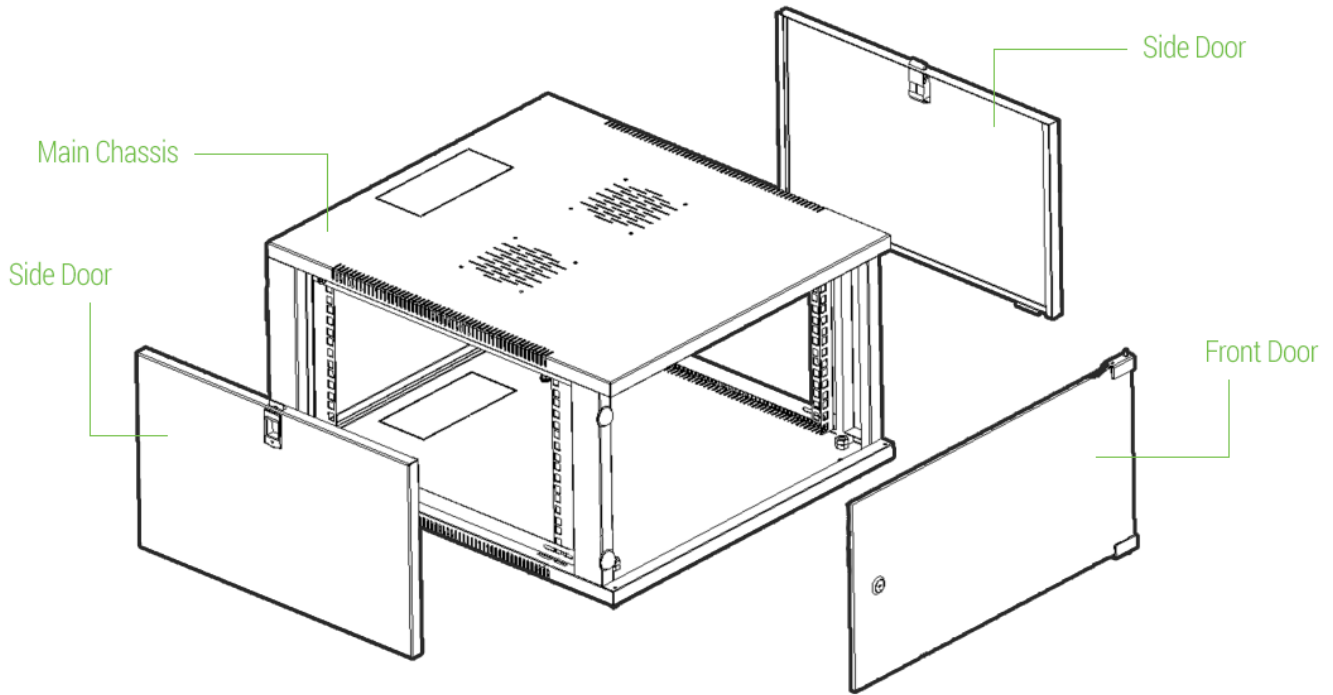

Part	Material	Surface
Main Chassis	SPCC Cold-Rolled Steel 1.0mm	Powder Coated/Vented Front & Sides
Side Door	SPCC Cold-Rolled Steel 1.0mm	Powder Coated
Front Door	Toughened Glass 5mm	

Ordering Information

Using the available configurations amend/create product codes using the formula below.

Linxcom		Colour		Depth	
Linxcom	LXM	Black	BLK	450mm	4
		Grey	GRY	600mm	6
LXM	Q	BLK	5	6	12
Model		Width		U Capacity (Height)	
Model Q	Q	540mm	5	15U (770mm)	15
				12U (635mm)	12
				9U (500mm)	09
				6U (370mm)	06

Example: **LXMQLK5612** - Linxcom Model Q 12U 540*600mm Black Wall Cabinet

For any queries, please contact the Linxcom team using the details below.